



K+ SERIES: UFWWSPK-1 Single Hole Waterless Stock Pot Cooker

Project: _____ Item: _____



UFWWSPK-1

Standard Features:

- Stainless Steel External Frame
- Heavy Duty Mild Steel Internal Frame
- Long Skirt Cast Iron Unflued Ring (340mm Diameter)
- Waterless feature eliminates deck cooling
- Heavy Duty Lever Action Gas Control
- Manual Operated Laundry Arm
- Flame Failure Device Standard
- Front access to all components makes service easy
- 12-Month Warranty

Options:

- Natural or LP Gas
- 18 Jet Duck Bill Burner (DB)
- 24 Jet Chimney Burner (CB)
- Not available with Castors

Specifications:

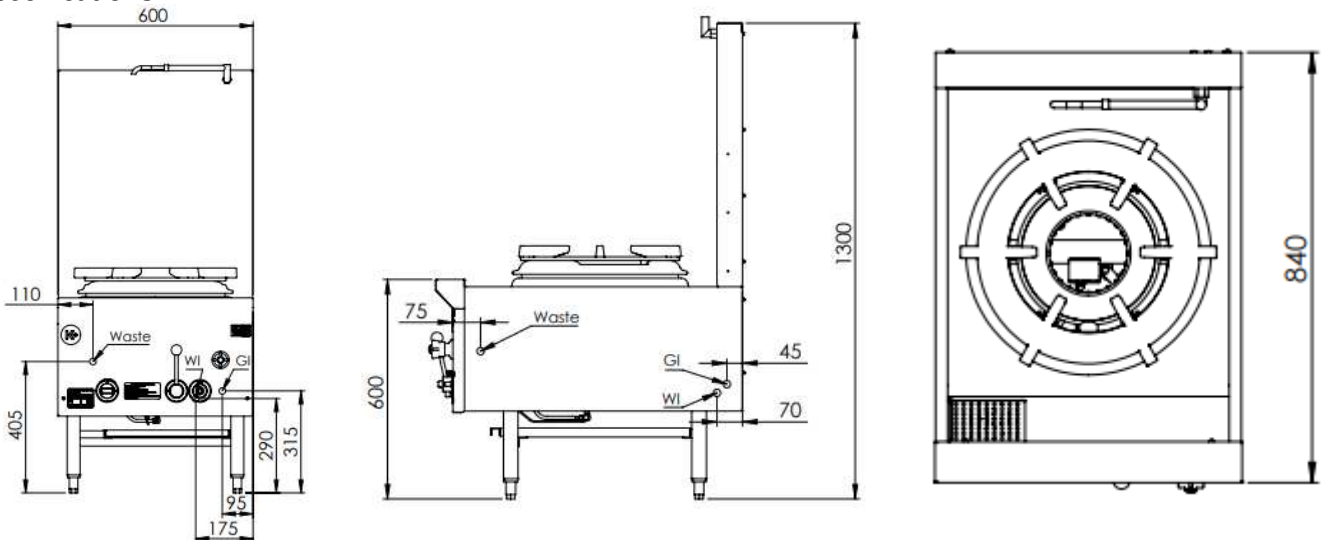

MODEL	LENGTH (mm)	DEPTH (mm)	HEIGHT (mm)	GAS CONSUMPTION (MJ/h)			
				NG - CB	NG - DB	LPG - CB	LPG - DB
UFWWSPK-1	600	840	1300	105	126	75	90

Connections:

GAS (GI) (BSP)	WATER (WI)	WASTE (W) (BSP)	SUPPLY PRESSURE (kPa)	
			NG	LPG
¾" (M)	½" (Copper)	2" (M)	1.0	2.6

- Regulator is included in the unit
- **Must** be installed by an authorised installer

Due to ongoing Product Development, Product Improvement and Research, B+S Commercial Kitchens reserves the right to alter specification without notice.



B+S Commercial Kitchens
57 Plateau Road Reservoir VIC 3073 Australia | +61 3 9469 4754
info@bscommercialkitchens.com | www.bscommercialkitchens.com

