



K+ SERIES: KNC-6 Noodle Cooker

Project: _____ Item: _____



KNC-6

Standard Features:

- Stainless Steel Frame
- 1.5mm Thick Stainless Steel Constructed Pan
- Energy-Efficient Target Burner
- Over-Temperature Safety Switch
- 21L Water Capacity Pan
- Manual Operated Laundry Arm and Tap
- Piezo Ignition and Flame Failure Standard
- Noodle Baskets Included
- Front access to all components makes service easy
- 12-Month Warranty

Options:

- Natural or LP Gas

Specifications:

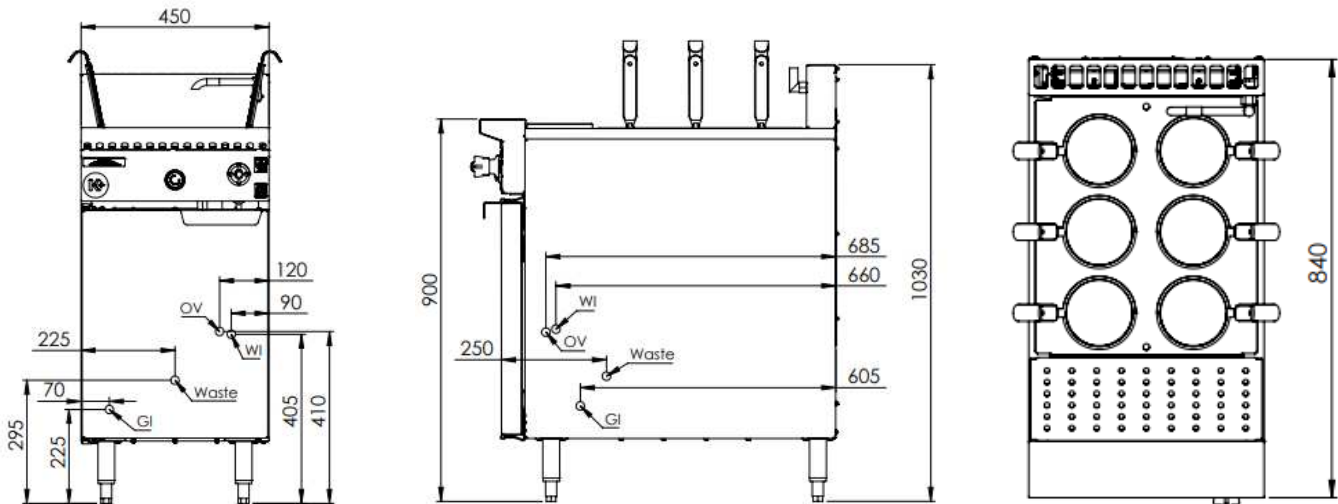

MODEL	LENGTH (mm)	DEPTH (mm)	HEIGHT (mm)	GAS CONSUMPTION (Mj/h)	
				NG	LPG
KNC-6	450	840	1030	70	75

Connections:

GAS (GI) (BSP)	WATER (WI)	WASTE (W) (HOSE & BSP)	SUPPLY PRESSURE (kPa)	
			NG	LPG
¾" (M)	½" (Copper)	Waste = 1" (F) OV = 1" (M)	1.0	2.6

- Regulator is included in the unit
- **Must** be installed by an authorised installer

Due to ongoing Product Development, Product Improvement and Research, B+S Commercial Kitchens reserves the right to alter specification without notice.



B+S Commercial Kitchens
57 Plateau Road Reservoir VIC 3073 Australia | +61 3 9469 4754
info@bscommercialkitchens.com | www.bscommercialkitchens.com

