

## Technical Specifications for SM-60



### PROFESSIONAL

- Efficient infrared gas burner technology
- Independent burners allow maximum control
- Compact with wall mounting brackets standard
- Modular Professional series design
- 15 month 'Platinum Warranty'
- Easy to clean and service

#### Griller/Toaster

- 11mj infrared burners with pilot, FFD and piezo ignition
- Variable flame control valve with low flame setting
- Multiple (4) toasting rack positions
- Toasting rack 440mm x 320mm
- Stainless steel interior panels
- Crumb tray at base of toaster
- Infrared burners do not cause 'drying' effect
- Optimal toasting results with burner on 'high' setting
- Lower flame settings ideal for melts/warming
- Standard with heavy duty wall mounting brackets

#### Overall Construction

- Heavy duty construction
- Welded 1.2mm 304 stainless steel front hob
- Front and side panels 0.9mm stainless steel
- Top cover 1.2mm stainless steel
- Stainless steel legs with 20mm height adjustment range

#### Dimensions

- 600mm x 445mm x 560mm H
- Weight 37kg
- Packed dimensions 660mm x 650mm x 750mm H
- Packed weight 52kg

#### Connections

- Gas 1/2" BSP male
- 80mm from right, 0mm from rear, 120mm from bottom
- Supplied with gas regulator (specify Nat or LP on order)

#### Cleaning & Servicing

- Removable toaster rack tray and supports
- Easy access to all parts & components from front

#### Options/Accessories

- Custom 600 wide bench with mounting brackets
- Extended warranty

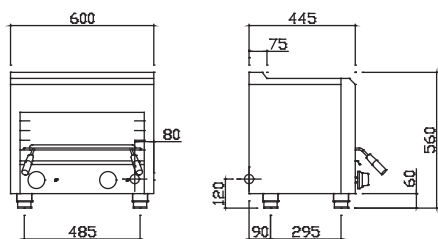

(Standard/Freestanding)

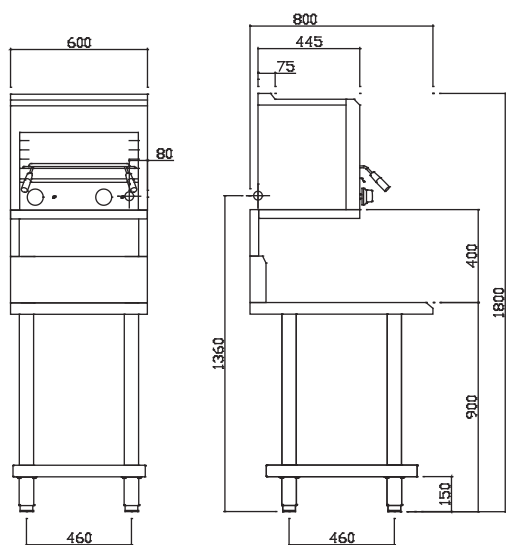

(With 600 Bench Option)

Key:  
 Gas

Model	Description	Nat Gas	LP Gas
SM-60	600 wide Salamander	22 mj	22 mj