

MANTOVA

# Real Tuff Shelving

---



PATENT PENDING

**PRODUCT GUIDE & SPECIFICATIONS**

# Real Tuff Shelving

Australia's most popular commercial shelving is now stronger, neater and easier to clean for the same price as it was in 2008 because it's 100% Made in Australia for Australian businesses.

## Key Features

- 100% Australian Made
- Will hold 250kg per level
- Australian Warranty
- 100% Recyclable
- Quick, Easy Assembly
- Anti Microbial built in
- Corrosion Resistant
- Adjustable every 50mm

## Shelf Sizes

All shelf sizes in "ALLGAL" and Stainless Steel kept in stock

- Widths  
300, 450, 525 and 600mm
- Lengths  
600, 750, 900, 1050, 1200, 1350, 1500, 1650 and 1800mm
- Post Sizes  
200, 1200, 1800 and 2000mm

## Finishes

- 304 Grade Stainless Steel
- "ALLGAL" Galvanised inside and out

## Dimensions

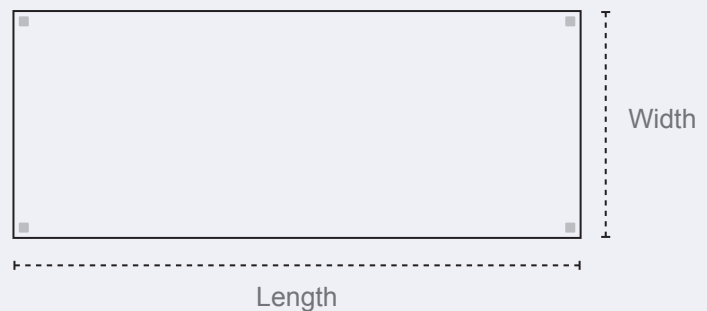

## Configurations



Starter Bay  
Holds 250kg per level



Add-On Unit  
Holds 150kg per level



Corner Unit  
Holds 150kg or 200kg per level



 **-30°C to**  **90°C**



**250 KG per level**

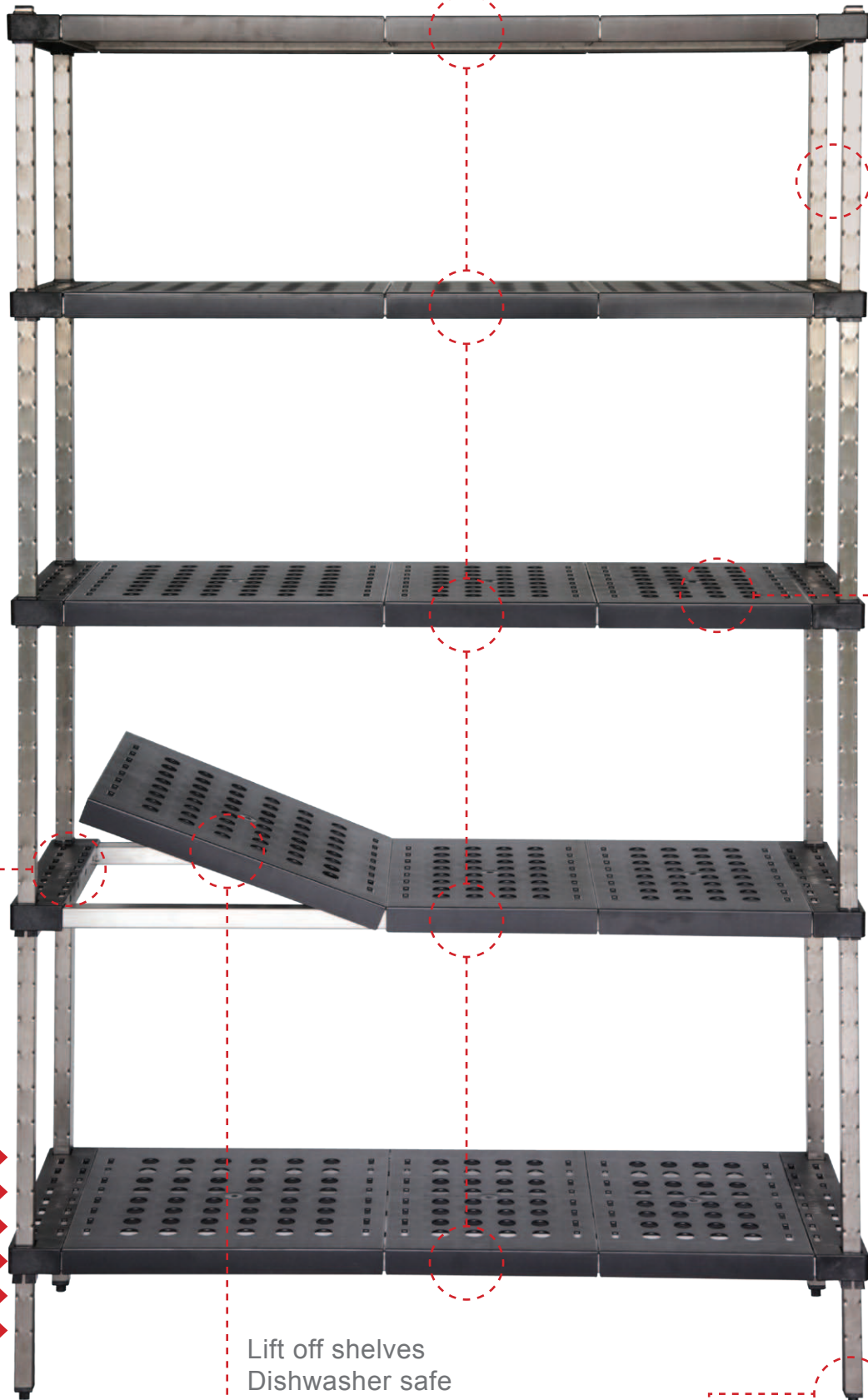

Two finishes available

Anti Microbial protection built in

New moulded shelf ends are 30% stronger

Lift off shelves  
Dishwasher safe  
Quick and easy to clean

Adjustable every 50mm, means you can have as many shelves as you need

Mantova bullet foot allowing 30mm of adjustment

# Accessories

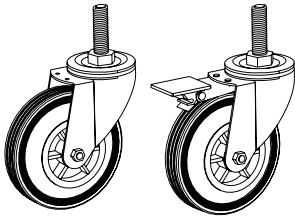

No Brake

Brake

## Castors -

Make shelving mobile, manoeuvrable and easy to relocate.

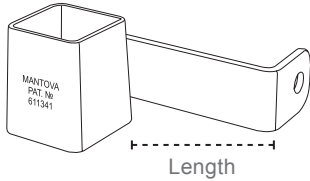

## Wall Fix Bracket -

Used for fixing shelving to a wall for added stability.  
Available in 2 lengths: 60mm and 150mm.

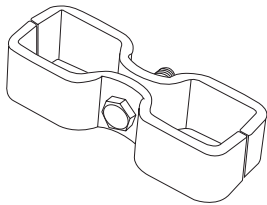

## Post Clamps -

Designed to structurally reinforce adjoining shelving units setup to store heavy loads.

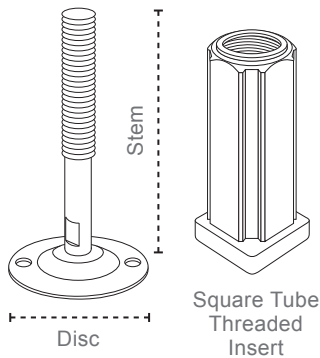

## Adjustable Feet -

Stainless Steel disc feet offer great adjustment for uneven flooring and can be fastened to the floor. (Posts come assembled with inserts)

Disc Feet Sizes with 16mm Thread:

105mm Stem x 65mm Disc

70mm Stem x 65mm Disc

105mm Stem x 50mm Disc

70mm Stem x 50mm Disc

---

## HOW TO ORDER

Mantova products are sold through distributors only.  
A full listing of distributors Australia wide are available on our website.



Manufacturer of high quality products for the Hospitality, Catering and Food Service Industries for over 40 years.

[View our full product range online](http://www.mantova.com.au)

[WWW.MANTOVA.COM.AU](http://www.mantova.com.au)